



英格爾科技股份有限公司

ENG ELECTRIC CO., LTD.

Revision 01

Approval Sheet

CUSTOMER: AF55A





CUSTOMER MODEL NO.: _____

ENG MODEL NO.: 3A-055WU05

ENG PART NO.: @3A-055WU05-079

DESCRIPTION: Switching Power Supply

DATE: 2011/10/6

PREPARED	DESIGNED	CHECKED	APPROVED
			

APPROVAL DATE:

CUSTOMER APPROVAL		

總部：台灣桃園縣龜山鄉民生北路 1段536號5樓

Head Office: 5F,NO.536, Sec.1, Min Sheng N. Rd.,Kweishan Hsiang,Taoyuan Hsien,Taiwan

TEL: 886-3-2121122 / FAX: 886-3-2121560

工廠：深圳市寶安區福永鎮白石廈中核集團B棟
Factory: Block B, Nuclear Group industrial District
Baishixia, Fuyung Town, Bao'an, Shenzhen, China
TEL: 86-755-27307512, 27307515
FAX: 86-755-27308049

工廠：中國廣東省東莞市塘廈鎮林村西湖工業區
Factory: Lin Village, Xi-Hu Industrial Area,
Dong-guan City, Guang-Dong, China
TEL: 86-769-87934928
FAX: 86-769-87930899

SHENZHEN ENG ELECTRONICS CO., LTD.

FILE NO.:EN-RDS-T411

FILE: @3A-055WU05-079

SHEET: 01

1. Product characteristics

1.1 General Description

Model 3A-055WU05 is a universal switching-mode power supply, operating at input voltage 90VAC to 264VAC and output voltage of 5.0VDC with 1.0A DC load

1.2 Electric Characteristics

1.2.1 Input

No	ITEM	SPECIFICATION
1.	Rated input Voltage	AC100V-240V
	Vibration input Voltage Range	AC90V-264V
2.	Frequency Rated	50-60Hz
	Frequency Vibration	47-63Hz
3.	Input Rated Current	300mA RMS Max
	Inrush Current	30A Max .at 115vac cool start
		60A Max. at 230vac cool start
4.	Leakage current	0.1mA
5	Efficiency	68.3% Min. CEC V Compliant
6.	Input power(no load)	<0.3W CEC Compliant

SHENZHEN ENG ELECTRONICS CO., LTD.

FILE NO.: EN-RDS-T411

FILE: @3A-055WU05-079

SHEET:02

1.2.2: Output:

No	ITEM	SPECIFICATION	
1.	output Voltage	5.0VDC	
2.	output max. current	1.0A	
3.	output min. Current	0A	
4.	Line regulation	± 3%	
5.	output Voltage tolerance	±5%	
6.	Over voltage protection	Protect through primary circuit IC	
7.	Short circuit protection	Output shut down and auto restart	
8.	Ripple Voltage	150mV (p-p)	Input :(100V-240VAC)
			Output:full load

Note: *1. Ripple&Noise test: Use 20MHz band width frequency oscilloscope.Add 0.1uF/47uF Capacitors at output connector terminal.

1.2.3 HI-POT SPECIFICATION

Input to output : 3000VAC or 4242VDC 10mA 1 minute.

1.2.4 Insulation resistance:

Input to output: 500Vdc to test the input to output resistance not be less 100M Ohm

1.2.5 Safety approved:

Type(Marking)	Country/Region	Standard
UL/CUL	USA/Canda	Safety : UL 60950-1
		Safety : CSA C22.2 No 60950-1-07
FCC	USA	EMI : FCC Part 15, SubpartB , Class B
CB	IEC	Safety : IEC 60950-1

SHENZHEN ENG ELECTRONICS CO., LTD.

FILE NO.: EN-RDS-T411

FILE: @3A-055WU05-079

SHEET:02

CE	Europe	In accordance with the council directive 2004/108/EC Adapter Standard : EN61204-3 EMI : EN55022 EMS : EN55024 ErP 278/2009
-----------	---------------	---

1.2.7 PB-free standard:RoHS Compliant

SHENZHEN ENG ELECTRONICS CO., LTD.

FILE NO.: EN-RDS-T411

FILE: @3A-055WU05-079

SHEET: 03

1.3

1.3.1 AC Plug: INLET Type:UL

1.3.2 DC cord:

(1)Bending test: Life 1000 times 100% guarantee. Swings 120 from

Left to right loading weight 200g , 40 cycle/minute.

(2)Pull test : DC cord and plug ,weight 6kg for 1 minute.

1.3.3 Cord length and output plug: See Reference Att.4

1.3.4 Weight : _____ g

1.3.5 Case Size: (L)54.2 X (W)32.7X (H)30.5mm

1.3.6 Normal operating temperature and humidity

1.3.7 Temperature

Operating: 0 °C to 40°C

Storage : -10°C to 70°C

1.3.8 Humidity

Operating : 20% to 80%.

Storage: 10% to 90%

SHENZHEN ENG ELECTRONICS CO., LTD.

FILE NO.: EN-RDS-T411

FILE: @3A-055WU05-079

SHEET: 04

2.Attachment:

- (Att.1) Label**
- (Att.2) Outdrawing**
- (Att.3) Package**
- (Att.3.1) Package flow chart**
- (Att.4) DC cord drawing**
- (Att.5) Electrical test report**

Att.1

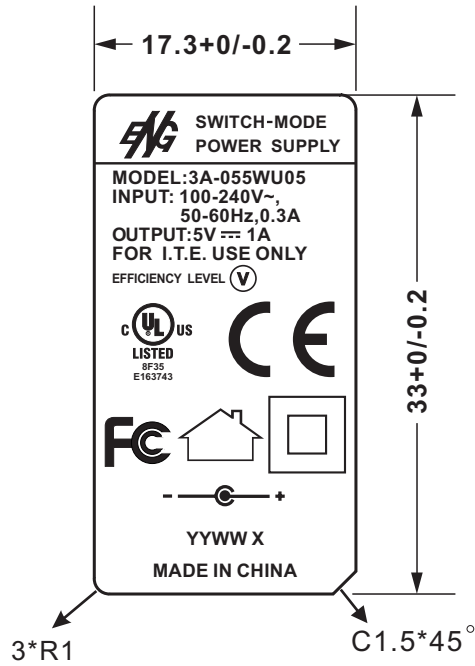

UNIT: mm

YYWW X YY:YEAR WW:WEEK X=S or A(S:FU YONG A:DONG GUAN)

ALUMINUM NAMEPLATE: ○ BLACK WORD ON SILVER BASE (銀底黑字)
鋁板

○ SILVER WORD ON BLACK BASE (黑底銀字)

METALIZED POLYESTER: ○ BLACK WORD ON SILVER BASE (銀底黑字)
消銀龍
(SILVER MATTE)

● SILVER WORD ON BLACK BASE (黑底銀字)

TOLERANCE

@3A-055WU05-079

DESIGNED	CHECKED	APPROVED		TITLE	LABEL	DATE
Wangs	Tianm	LNB		UNITS		mm
				SCALE	2:1	
SHENZHEN ENG ELECTRONICS CO., LTD.				DRAWING NAME		REVISION
				0318		01

Att.2

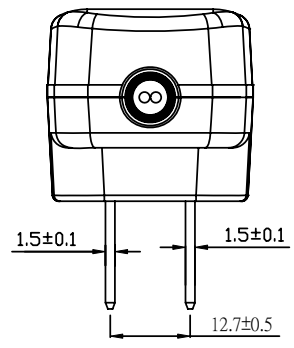
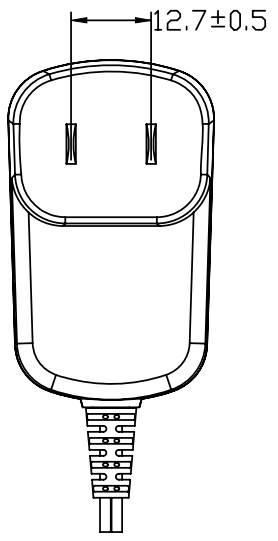
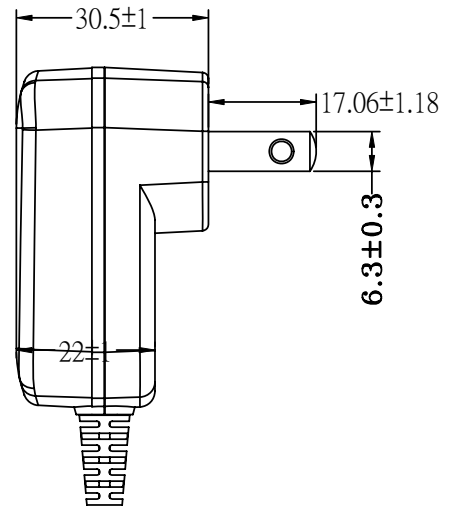
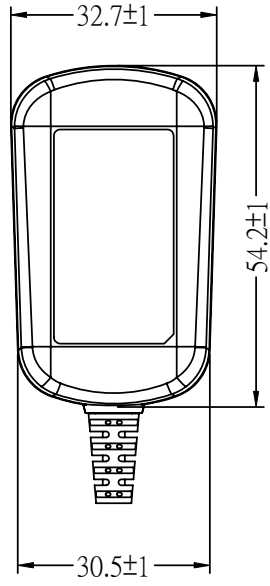

TOLERANCE				

DESIGNED	CHECKED	APPROVED		TITLE	DATE
TFL	JF	Lnb		UNITS	OUTDRAWING
			SCALE	DRAWING No.	11/03/24
SHENZHEN ENG ELECTRONICS CO., LTD.				DRAWING NAME	REVISION
				031801-001	01
				031801	

ATT. 3

CARTON SIZE: 455X389X326mm(A=B 6mm)
 紙箱尺寸: 455X389X326mm
 PARTITION BOARD: 442X376X3mm(6pcs)(B33)
 CROSS-CONNECTING BOARD: 442X57X6mm(25pcs)(B=C)
 CROSS-CONNECTING BOARD: 376X57X6mm(55PCS)(B=C)
 Q' TY: 200pcs(40x5)
 數量: 200pcs(40x5)

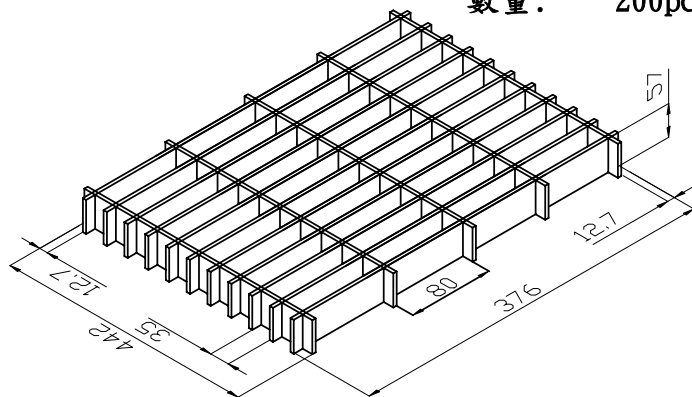

CELL PARTITION

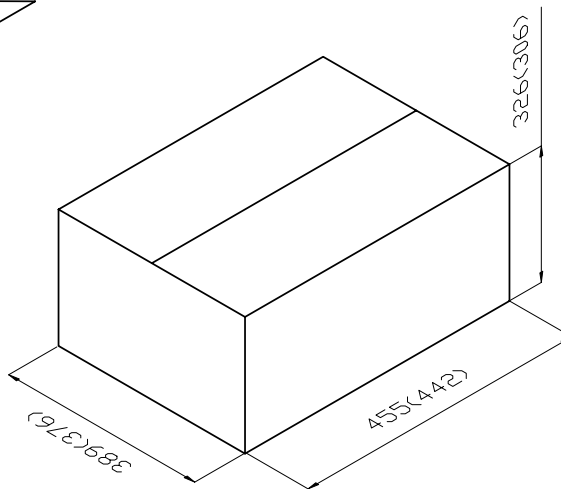
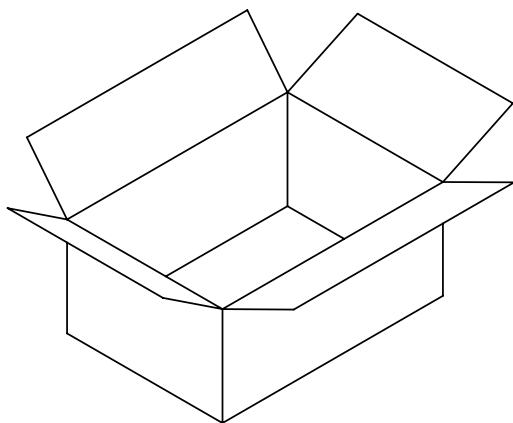

The tolerance of the internal dimensions of the carton is +7/-0
 紙箱內度尺寸公差為+7/-0

TOLERANCE				

DESIGNED	CHECKED	APPROVED		TITLE	DATE
Wangs	Tianm	lnb		UNITS	PACKAGE
SHENZHEN ENG ELECTRONICS CO., LTD.			mm	DRAWING No.	REVISION
			SCALE	PBG-4050-V-55	
				DRAWING NAME	
				BG-4050-V-55	

ATT. 3.1

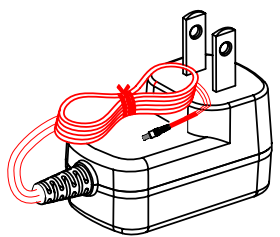

PE袋(SIZE:110X200mm)

1PCS放入同一格

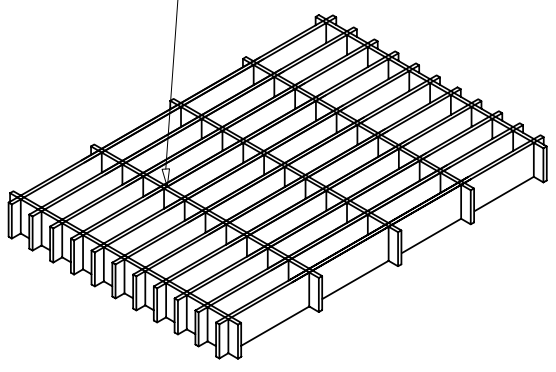

CELL PARTITION

TOLERANCE				

DESIGNED	CHECKED	APPROVED		TITLE	DATE
Wangs	Tianm	LNB		UNITS	PACKAGE FLOW CHART
SHENZHEN ENG ELECTRONICS CO., LTD.				DRAWING No.	REVISION
				@3A-055WU05-079	01
				DRAWING NAME	
				110*200	

Att.4

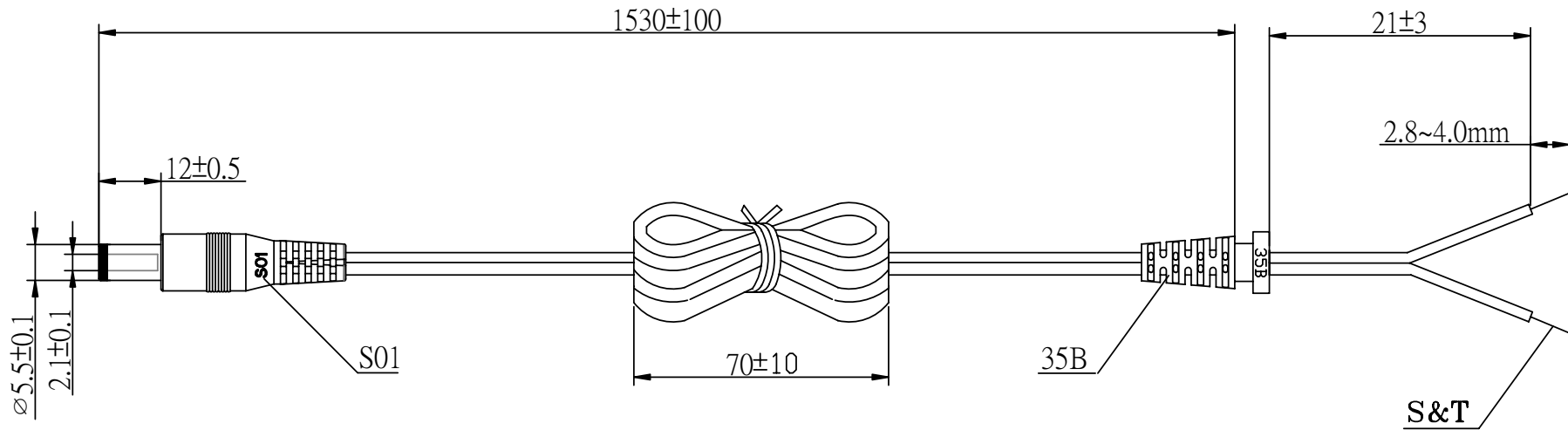

#22AWGX2C UL2468 HAVE ON WORD WIRE IN OUTER, NO WORD WIRE IN INNER(有字接外，無字接內)
 OD: $\varnothing 1.7 \times 3.4$

TOLERANCE				

Parameter request	
搖擺測試 VIBRATION TEST	a. $\pm 60^\circ$ b. 吊重200g WEIGHT 200g c. 40回/分 40 ROUND/MINUTE d. 1000次/最少 OVER 1000 COUNT MIN

DESIGNED	CHECKED	APPROVED		TITLE	DATE
LQiang	Tianm	LNB		UNITS mm SCALE	DC CORD DRAWING No. @3A-055WU05-079
SHENZHEN ENG ELECTRONICS CO., LTD.				DRAWING NAME 21-35BS01-03B-00	REVISION 01